

GAE WaveLine



The construction determines an extremely low crossover frequency to the compression driver which optimizes the horizontal dispersion of the system. Because of the high radiation-resistance the overall system comes up with an outstanding mid-tone performance. As the double-10"-construction enables a low tuning frequency of 80Hz, a smooth transition to a subwoofer, employed in ground stacking, is guaranteed. Beyond that the GAE Director Waveline System displays an enormous efficiency in full range application.

Deduced from the experiences made with the twin-coaxial principle used with the GAE Director Top an extremely exact symmetric dispersion could be established in the Waveline System. The overall construction is left/right symmetric, thus a concise utilization for the user and fitter results.

The GAE Waveline line-array system represents the result of an intensive physical and economic investigation into the market necessities in the field of touring and installation. Based on the experience of users and consultants a huge variety of approaches has been considered. The essence of these reflections builds special options for the development and – designing the Waveline System – has been put into practice:

The combination of two 10" Neodymium transducers of the low-/mid range, each incorporating a 3" voice coil, allows a very low crossover frequency, which raises drastically the power handling capacity. This way the Waveline System is suitable for non-restrictive full range use. The GAE HF-Phase-EQ coupled to a high power 2" Neodymium-driver achieves an accurate and highly exact sound conduction in the high-tone range, which results in an extended high frequency bandwidth.



GAE WaveLine

Furthermore the development aimed at the realization of an economic array-length-/prize-proportion. To reach this goal each WaveLine element has been outfitted with a nominal impedance of 8 ohms in the high- as well as in the low-/mid-tone range, thus three elements can be operated at one amplifier. In this way by the help of only three elements and one amplifier a vertical angle of 30° can be achieved as minimal configuration. This elemental set-up can be extended with further Waveline elements. By employing modern system controllers the peripheral electronics equipment can be limited to a sensible measure.

Users already owning a GAE Director System can easily make use of the Director Waveline System as the preexisting amp-racks can be operated compatibly. The only item needed additionally is an 8-pin-CaCom adapter box on Neutrik 4-pin-Speakon.



The very discreet flying mechanic is let in the loudspeaker's enclosure without attracting attention. On request the handles on the front can be removed and the lateral recesses covered. The whole process of mounting- and demounting has been optimally matched to all user's demands.

For flying mechanics only high quality and determinate materials are applied. The load distribution is forwarded solely in the flight elements. Apart from locking quick release pins no bulk parts are needed.

GAE WaveLine

GAE WaveLine-system's rigging mechanics together with the flying-cradle are certified according to Germans BGV-C1 and DIN 18800. An analysis of strength can be achieved by a free-of-charge software (GAE's Flying Calculator) which shows easily the legality of your rigging job.



The stack-cradle together with the attached outriggers enable the mounting of up to 6 WaveLine elements as ground-stacking. The frame of the stack-cradle fits to GAE's basses BR118, BR218, Director-Bass and Director-Single-Bass and enables a secure mounting of 3 WaveLine elements.



For simulation and calculating of acoustical configurations GAE provides the EASE Focus Aiming Software from SDA (Software Design Ahnert GmbH). The EASE Focus Aiming Software is a two-dimensional acoustic simulation software that serves for the configuration and modelling of Line-Arrays close to reality.

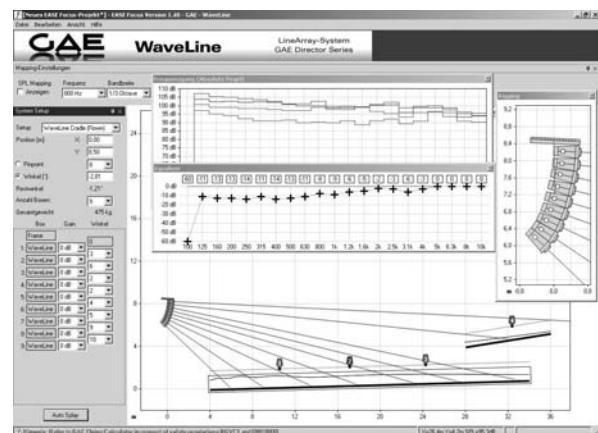

Ease Focus and the specific product file (GAE-WaveLine.efo) together with GAE's Flying Calculator are available as free download from GAE's web-site.

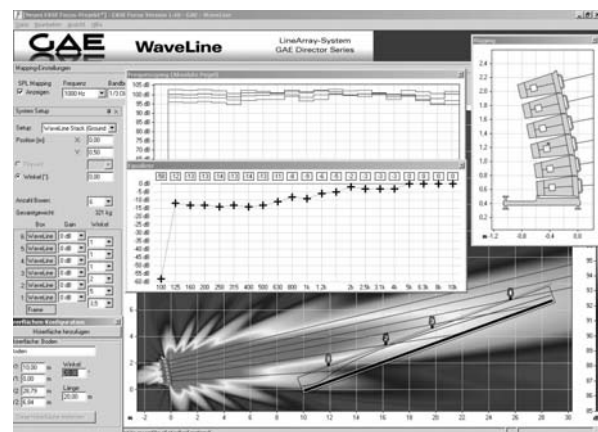

GAE WaveLine

Technical Specifications GAE WaveLine

Type	2-way full-range twincoaxial line-array-system, vented/hornloaded
Frequency response	80 Hz – 18 kHz, +/- 3 dB
Power handling capacity	LMF 500 W, HF 120 W IEC norm 268-5
Impedance	LMF 8 ohms, HF 8 ohms
Recommended input power	LMF 750 – 1500 W into 8 ohms, HF 200 – 480 W into 8 ohms
Dispersion	horizontal 110° symmetrical; vertical 0°...10° defined by array adjustment
Sensitivity	LMF 100dB (1W / 1m), HF 110 dB (1W / 1m)
Peak SPL (1m)	single enclosure > 130 dB
Components	2x 10" N/Dym, 3" voice coil, water-resistant; 1x 2" N/Dym compression driver on GAE HF-Phase-EQ
Connectors	2 x NL4MP Neutrik Speakon
Rigging/Fittings	GAE flyware, completely integrated; 2 handling recesses at side-walls; 2 aluminium handles at the front
Enclosure	multi-layered birch-ply 15mm enclosure, aluminium covers 4mm
Sealing	environment-friendly structure varnish on water-basis, non-abrasive
Colours	standard black, equivalent to RAL9005, other colours on request
Front protection	solid frontgrill with stylish acoustic foam
Weight	WaveLine-element: 48,5kgs; Flying-cradle: 38,6kgs; Stack-cradle: 24kgs (frame: 12kgs, outrigger 2x6kgs)
Dimensions	Housing without handles/flyware 302/200 x 672 x 590 (mm), H x W x D; overall dimensions 332/200 x 672 x 647 (mm), H x W x D
Subwoofer	GAE BR118; BR218
System Controller	Setup settings for modern digital controllers
Optional accessories	Flying-cradle, Stack-cradle, Touring-Case for 3 elements, Touring case for Flying-cradle, Touring case for Stack-cradle, Software

Recommended subwoofer:



GAE BR118



GAE BR218



EtaMax

GAE WaveLine

Technical drawings GAE WaveLine

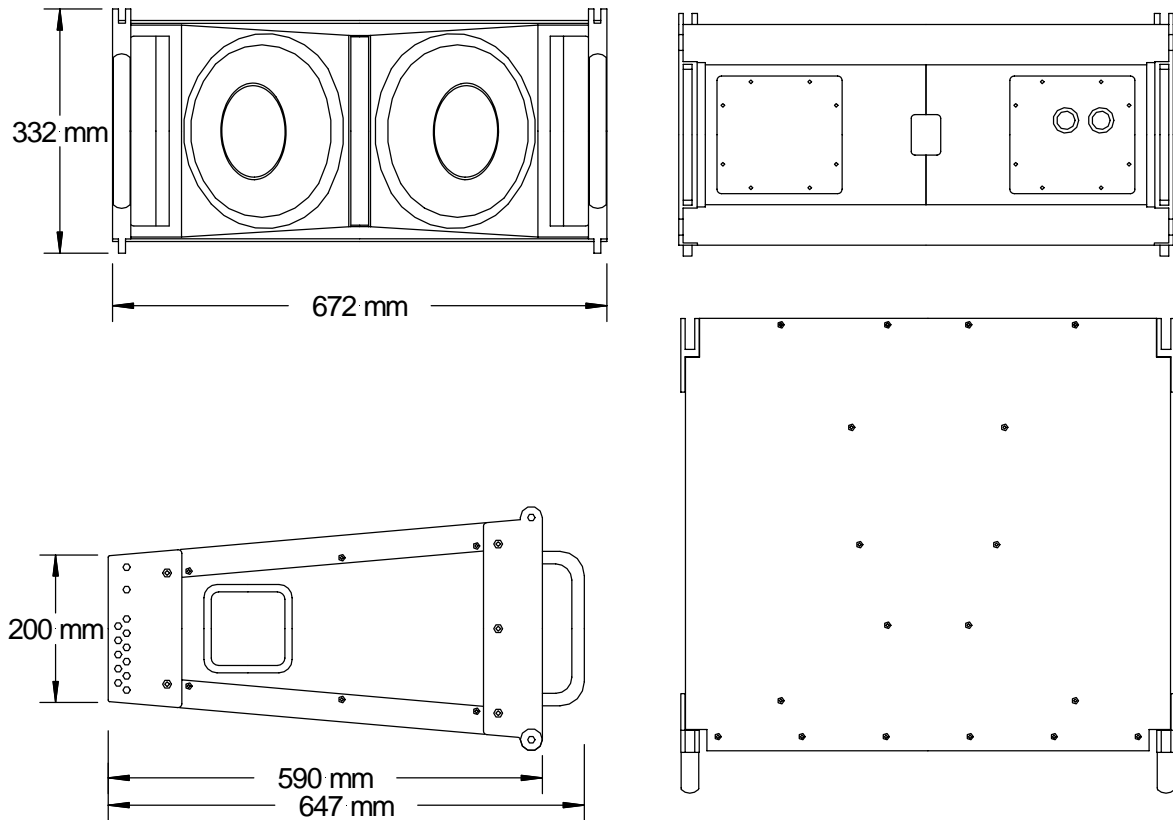

Recommended plugs: Neutrik Speakon Type NLT 4 FX.
Length of link cable between 2 WaveLine-elements: 65cm
Recommended cable: H07RN-F 4x2,5mm² / www.schulz-kabel.de.

GAE

GAE, Director and WaveLine are registered trademarks of
opal audio vertrieb GmbH,
Esch 13b
D-33824 Werther
Tel. +49-(0)5203-236, Fax +49-(0)5203-238
www.gae.de, info@gae.de

Technical modifications without notice.